

PRORIL

50Hz

GOVOX-S Series, these vortex pumps are equipped with an agitator, which forcibly agitate the fluid for easy and efficient transmission of sludge, sand, mud, and debris.

Sewage Pump

GOVOX-S 322/337

Vortex and Agitator Pump



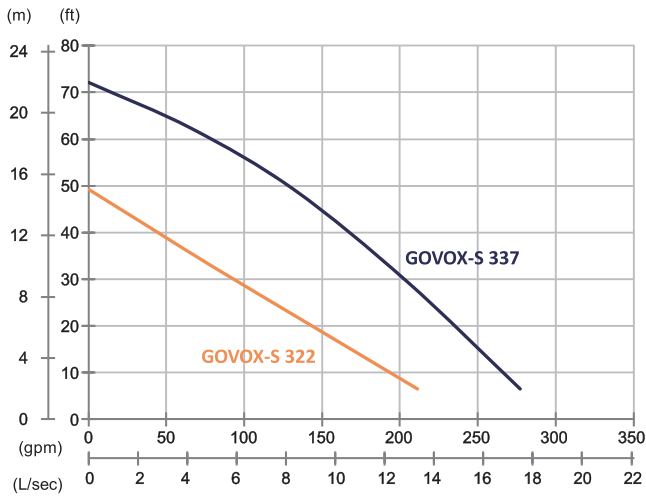

	GOVOX-S 322	GOVOX-S 337
OUTPUT	2.2 kW (3 HP)	3.7 kW (5HP)
OUTLET	3" (80 mm)	3" (80 mm)
SOLID PASSAGE	13 mm	13 mm
Weight	43 kg	53 kg
HEAD	Rated: 10 m Max: 15 m	Rated: 15 m Max: 22 m
FLOW	Rated: 5 L/s Max: 13.3L/s	Rated: 8.3 L/s Max: 17.5 L/s

Pump Type		Electric Submersible Pumps
Motor	Phase	3-Phase
	Type	Induction Motor
	Poles	2 Pole (2850 rpm)
	Insulation	Class F
	Protector	Circle Thermal Protector
	Starter	D.O.L.
Lubricant		Food Grade (ISO VG32)
Specs.	Impeller Type	Vortex
	Shaft Seal	Double Mechanical Seal
		Silicon Carbide VS Ceramic/Carbon
	Bearings	C3 Shielded ball bearings
	Cable	H07RN-F
10 m or longer upon request		
Materials	Pump Casing	Ductile Iron
	Impeller	Gray Iron
	Motor Frame	Gray Iron
	Motor Shaft	Stainless Steel
Max. Liquid Temperature		40°C (104°F)
Max. Submersion Depth		20 m (66 ft)
pH Range		pH 5 - pH 8

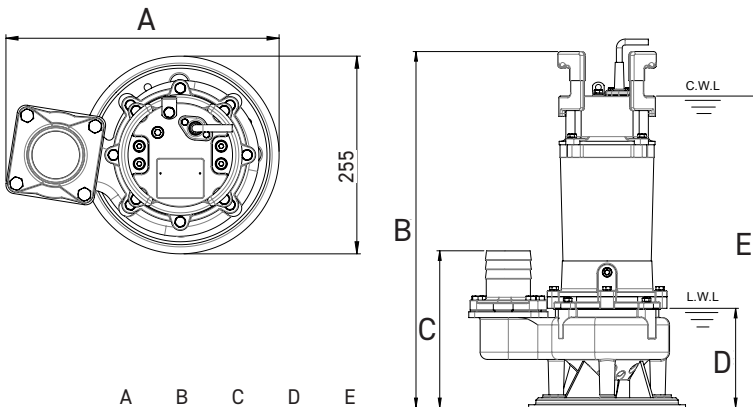

	A	B	C	D	E
GOVOX-S 322	373	665	270	155	636
GOVOX-S 337	383	718	275	160	590

unit : mm

C.W.L : Continuous running water level
L.W.L : Lowest running water level